

UNCONTROLLED DOCUMENT

CAUTION: STATIC SENSITIVE DEVICE  
FOLLOW PROPER E.S.D. HANDLING PROCEDURES  
WHEN WORKING WITH THIS PART.

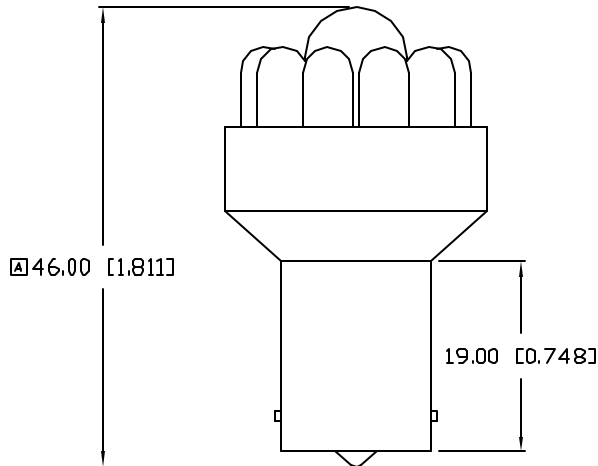
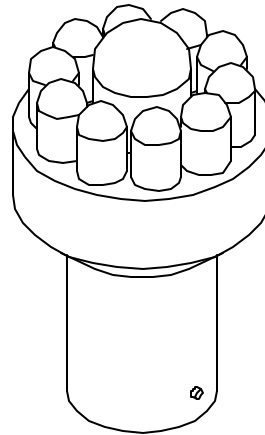
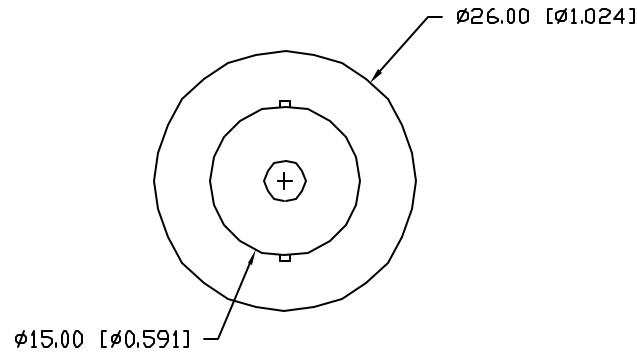

PART NUMBER		REV.
SSP-1156B15912		B
REV.	E.C.N. NUMBER AND REVISION COMMENTS	DATE
A	E.C.N. #10958.	2.26.03
B	E.C.N. #11025.	8.19.03

ELECTRO-OPTICAL CHARACTERISTICS  $T_A=25^{\circ}\text{C}$   $V_f=12\text{V}$

PARAMETER	MIN	TYP	MAX	UNITS	TEST COND
PEAK WAVELENGTH				nm	
FORWARD VOLTAGE		12.0	14.0	$V_f$	
REVERSE VOLTAGE	5.0			$V_r$	$I_f=100\mu\text{A}$
AXIAL INTENSITY		48000		mcd	$V_f=12\text{V}$
VIEWING ANGLE		20		2x theta	
EMITTED COLOR:	ULTRA WHITE				
EPOXY LENS FINISH:	WATER CLEAR LENS				

LIMITS OF SAFE OPERATION AT  $25^{\circ}\text{C}$  PER MODULE

PARAMETER	MAX	UNITS
PEAK FORWARD VOLTAGE	14	V
STEADY CURRENT	110	mA
POWER DISSIPATION	105	mW
DERATE FROM $25^{\circ}\text{C}$	-1.2	mW/ $^{\circ}\text{C}$
OPERATING, STORAGE TEMP.	-40 TO +85	$^{\circ}\text{C}$

\*UNLESS OTHERWISE SPECIFIED TOLERANCES PER DECIMAL PRECISION ARE: X=±1 (±0.039), XX=±0.5 (±0.020), XXX=±0.25 (±0.010), XXXX=±0.127 (±0.005). LEAD SIZE=±0.05 (±0.002), LEAD LENGTH=±0.75 (±0.030). MIN= <sup>+DECIMAL PRECISION</sup> -0.00 <sup>MAX.= +0.00</sup> -DECIMAL PRECISION

UNCONTROLLED DOCUMENT

REV. B	PART NUMBER SSP-1156B15912	CONFIDENTIAL INFORMATION THE INFORMATION CONTAINED IN THIS DOCUMENT IS THE PROPERTY OF SUNBRITE LEDS. EXCEPT AS SPECIFICALLY AUTHORIZED IN WRITING BY SUNBRITE LEDS, THE HOLDER OF THIS DOCUMENT SHALL KEEP ALL INFORMATION CONTAINED HEREIN CONFIDENTIAL AND SHALL PROTECT SAME IN WHOLE OR IN PART FROM DISCLOSURE AND DISSEMINATION TO ALL THIRD PARTIES.  RELIABILITY NOTE DUR MANY YEARS OF EXPERIENCE DATA ACCUMULATION INDICATE THAT SOLDER HEAT IS A MAJOR CAUSE OF EARLY AND FUTURE FAILURE. PLEASE PAY ATTENTION TO YOUR SOLDERING PROCESS.		286 E. HELEN ROAD PALATINE, IL 60067-6976 PHONE: +1.847.359.2790 FAX: +1.847.359.2867 WEB: www.sunbriteleds.com
1156 LED REPLACEMNT LAMP, WHITE.		DRAWN: BC	CHECKED:	APPROVED:
				DATE: 5.6.02 PAGE: 1 OF 1